

HORTON AUTOMATICS ICU MANUAL SLIDING DOORS

OWNERS INFORMATION

6-00

TRACKLESS UNITS

To obtain a full opening, doors must be in the swingout 90° position. This is accomplished in the following manner:

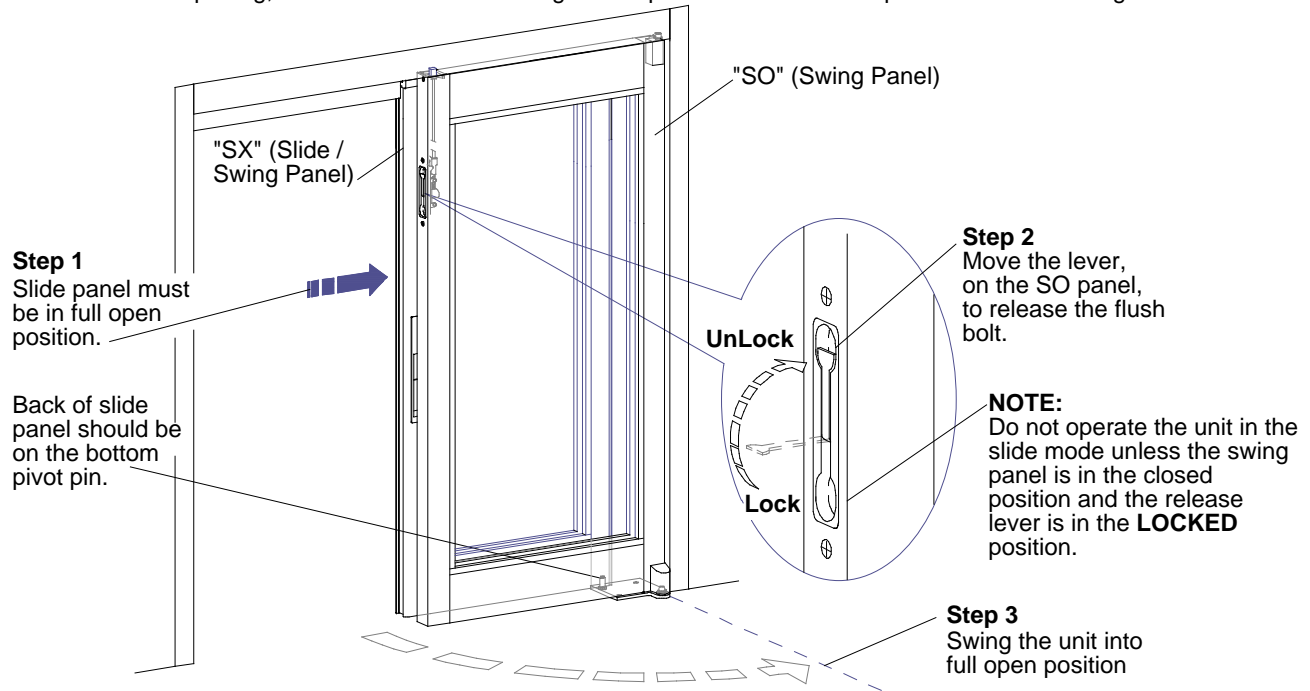

FLOOR TRACK UNITS

These units can be swing out from any slide position.

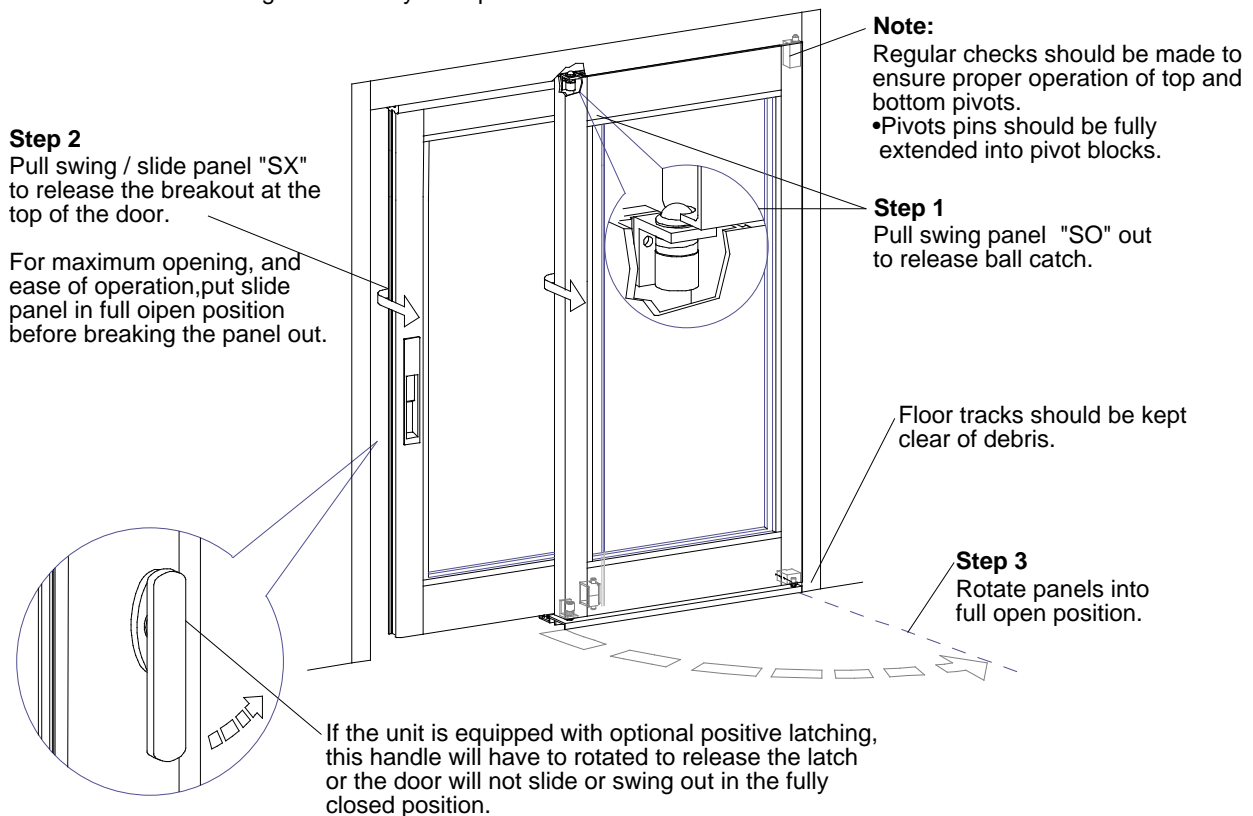

ICU / CCU MANUAL SLIDING DOORS

1. OWNER'S INFORMATION

We are pleased that you have chosen a manual ICU / CCU door from Horton Automatics. This door will provide many years of safe, reliable, operation provided the unit is properly installed and maintained. This Information is intended to serve as a guide for the Owner to become familiar with the operation and safety of this manual sliding door unit.

Regular inspections are required to keep each door in safe and proper working order. Please acquaint yourself with and follow all instructions on the other side of this page.

2. SERVICE AVAILABILITY

Horton Automatics' products are manufactured at the company's plant facilities in Corpus Christi, Texas and Telford, England. A worldwide network of authorized independent distributors offers both installation and a maintenance program. For the local Horton Automatics distributor in your area, call 1-800-531-3111 or 361-888-5591 (U.S. and Canada) or consult the Yellow Pages of your Telephone Book under "Door-Operating Devices." In Europe, call the Horton plant in Telford, England at 011-44-1952-670169 or fax at 011-1952-670181.

3. LIMITED WARRANTY

Horton Automatics (Seller) warrants to the Buyer all products they manufacture to be free from defects in material and workmanship, under normal use and service, for twelve months from the date product is placed in operation. The Seller's obligation under this warranty is limited to the repair or replacement at the factory, of any parts which shall be returned to the Seller with transportation charges prepaid and which after examination, prove to be defective. Said warranty shall not apply to such products which shall have been installed, altered, or repaired by any person not expressly authorized in writing for such purpose by the Seller, or subjected to misuse, negligence or accident. The aforesaid warranty is made expressly in lieu of other warranties, expressed or implied and in lieu of any other obligations or liabilities on the part of the Seller and the Seller neither assumes nor authorizes any person to assume for it any other liability or obligations in connection with the sale of such products to the Buyer.

THERE IS NO WARRANTY OF MERCHANTABILITY OR FITNESS FOR ANY PARTICULAR PURPOSE, NOR IS THERE ANY WARRANTY, EXPRESSED OR IMPLIED, EXCEPT AS SPECIFICALLY STATED ABOVE. SELLER SHALL NOT BE LIABLE FOR SPECIAL OR CONSEQUENTIAL DAMAGE, NOR FOR CLAIMS OF ANY THIRD PARTY AGAINST THE BUYER.

Generally, the installing distributor provides a one-year warranty covering the labor and transportation charges for defective parts replacement. If this is the customer's wish, it should be specified.

Distributed By: _____



A U T O M A T I C S
A Division of Overhead Door Corporation

4242 Baldwin Boulevard
Corpus Christi
Texas 78405-3399
800-531-3111
361-888-5591
Fax: 800-531-3108 361-888-6510

Internet: <http://www.hortondoors.com>

Horton Automatics, Ltd.
Unit A, Hortonwood 31
Telford, Shropshire
England TFI-7YZ
01952 670169
Fax: 0192 670181
International Telephone ++44-1952-670169
Fax: ++44-1952-670181

Form M301, 6/00
1997 Horton Automatics, printed in U.S.A.

Product equipment depicted in the various figure drawings are approximate and for illustration purposes only. Consult manufacturer for detail product specifications. Horton Automatics reserves the right to improve the product and change its specifications without notice.