

# **DOR-O-MATIC®**

## **AUTOMATIC DOOR SYSTEMS**

---

# **Benchmark Swing Operator**

Installation Instructions

95239-900 Standard  
95339-900 Premium



Copyright © 2003 Ingersoll-Rand. All rights reserved.

**DOR-O-MATIC®**  
**AUTOMATIC DOOR SYSTEMS**  
7350 West Wilson Avenue  
Harwood Heights, IL 60706-4708  
1-800-543-4635  
708-867-7400  
Technical Support: 1-888-942-9945  
Engineering Fax: 708-867-1177  
[www.doromatic.com](http://www.doromatic.com)

## CONTENTS

General .....	2
Replacement Parts and System Components .....	2
Pre-Installation Site and Product Check .....	4
Operator Installation .....	5
Wiring .....	9
Arm and Cover Installation .....	12
Operational Check .....	14
Operator Adjustment .....	15
Release for Service .....	16

## GENERAL

The Benchmark is an automatic electromechanical swinging door operator for indoor use on hinged, center pivoted, and offset pivoted doors. When activated, the Benchmark drives the door to the full open position, then electrical power is turned off and the door is closed by spring force. The activating circuit opens the door from any position in the closing swing. During a power failure, the Benchmark acts as a manual door closer (size 3). Door opening and closing cycles, including opening speed, back check speed, hold open time delay, closing speed, and latch position, are adjustable.

### **WARNING**

Always disconnect main power to the operator prior to servicing or cleaning.

### **CAUTION**

This operator is for indoor use only.

### **CAUTION**

Do not mount any accessories directly to the operator.

## REPLACEMENT PARTS AND SYSTEM COMPONENTS

Part	27" Header	Full Length Header Single	Full Length Header Double
Standard Control Box	95229-900	95229-900	95229-900
Premium Control Box	95329-900	95329-900	95329-900
Gear Box	95100-000	99040-000	95100-000
Cover	95171-9XXR	99201-9XXR	99201-9XXR
Insert	N/A	99067-9XX	N/A
End Caps	99060-900	99060-900	99060-900

Part	Pull	Standard Push	Extended Reveal Push
Arm Assembly	95085-9XX	95005-9XX	95025-9XX

XX	Finish
75	US 28
79	DC 13

# REPLACEMENT PARTS AND SYSTEM COMPONENTS (continued)

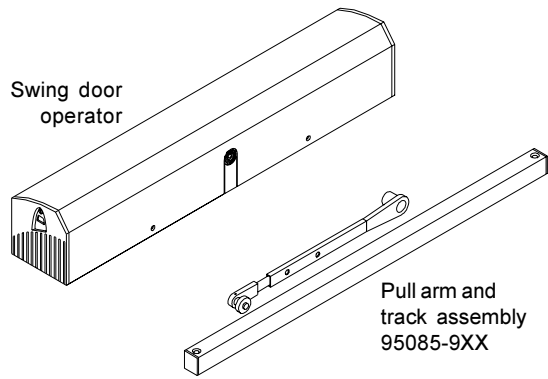

**27" Pull System**  
(screw pack not shown)

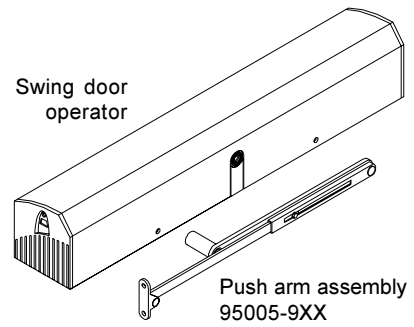

**27" Push System**  
(screw pack not shown)

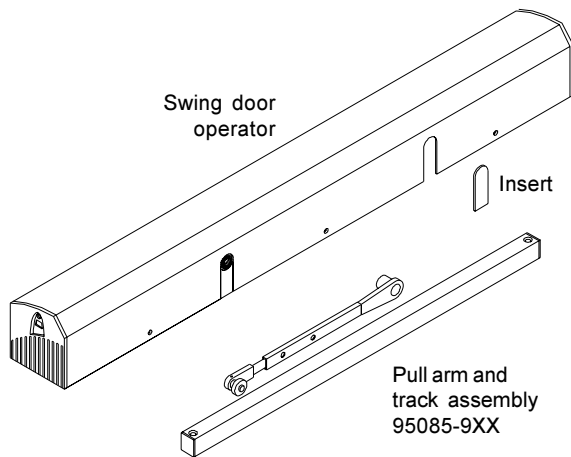

**Full Length Pull System**  
(screw pack not shown)

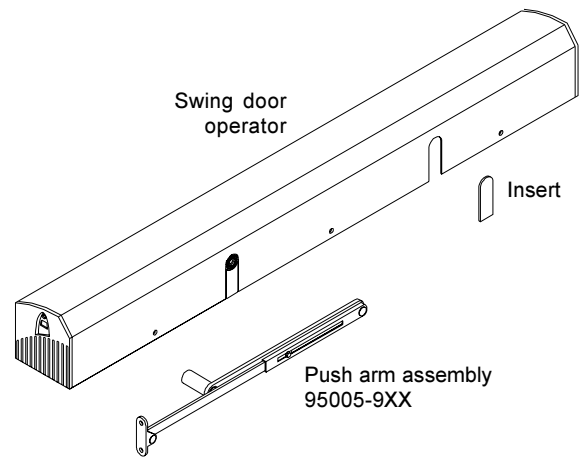

**Full Length Push System**  
(screw pack not shown)

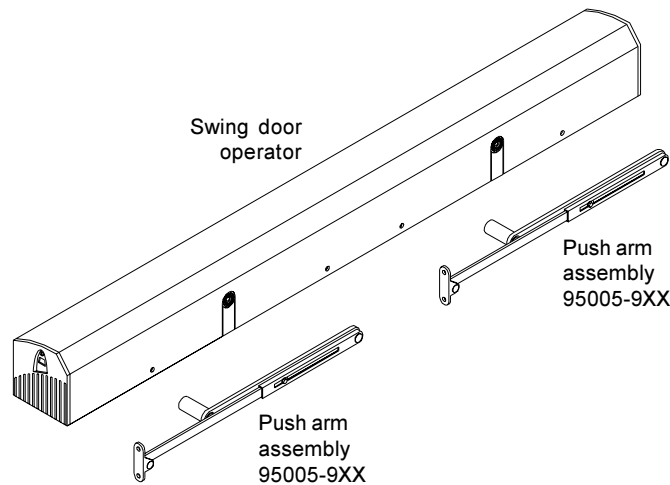

**Double Push System**  
(screw pack not shown)

## 1. PRE-INSTALLATION SITE AND PRODUCT CHECK

- 1.1. Check that the product model is correct for the required application.
- 1.2. Check that all parts listed on the bill of material are in the shipping container.
- 1.3. Check architectural drawings and final approved shop drawings for position of frame and structural openings.
- 1.4. Check header and frame dimensions and required clearances:

**Clearances for 27" Pull System and Full Length Pull System**

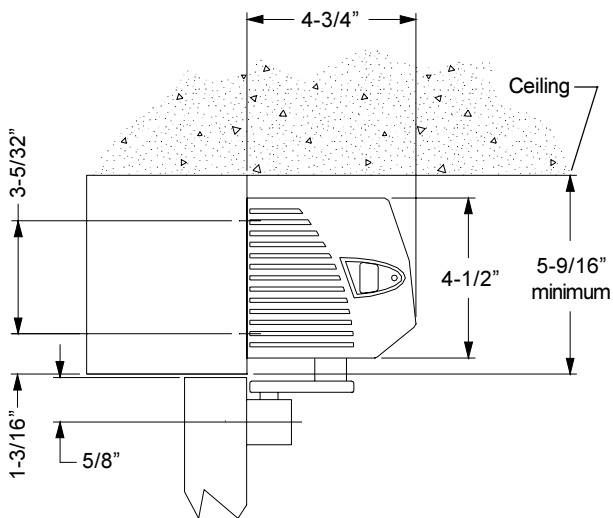

1-3/8" frame face minimum  
1-7/8" top rail in door minimum

**Clearances for 27" Push System, Full Length Push System, and Double Push System**

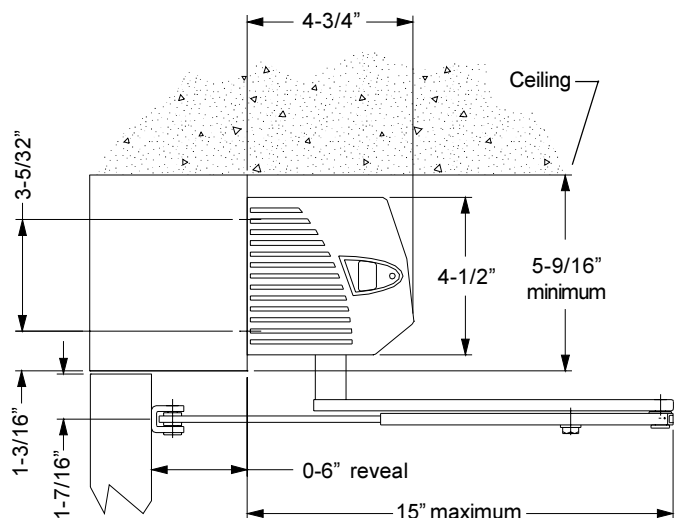

1-3/8" frame face minimum  
1-7/8" top rail in door minimum

- 1.5. Check door width: 26" minimum for 27" push operator  
30" minimum for 27" pull operator  
36" minimum for full length push or full length pull operator
- 1.6. Check that door weight is 200 lbs or less. For heavier doors, consult factory.
- 1.7. Check that a 115 volt, single phase, 60 Hz, fused, 15 amp, 3-wire power supply is available at the side jamb with approximately 12" of wire available to connect to the operator. UL approved type flexible conduit is recommended for the 115 volt power line.

The 115 volt power supply must be a dedicated circuit from the main circuit breaker panel and **must not** be connected into a building lighting system operating fluorescent lights.

## 2. OPERATOR INSTALLATION

- 2.1. Remove control box from operator mounting bracket, then remove motor/gearbox from bracket:

### Control Box and Motor/Gearbox Removal 27" Pull, 27" Push, and Double Push Systems

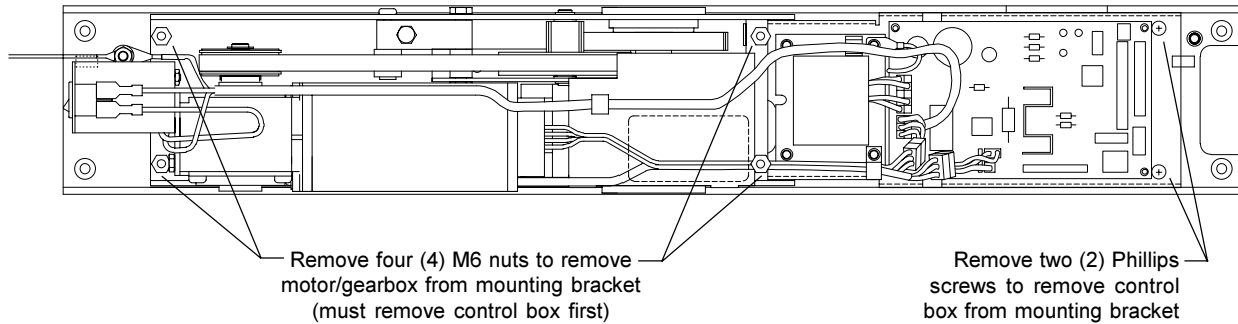

### Control Box and Motor/Gearbox Removal Full Length Pull and Full Length Push Systems

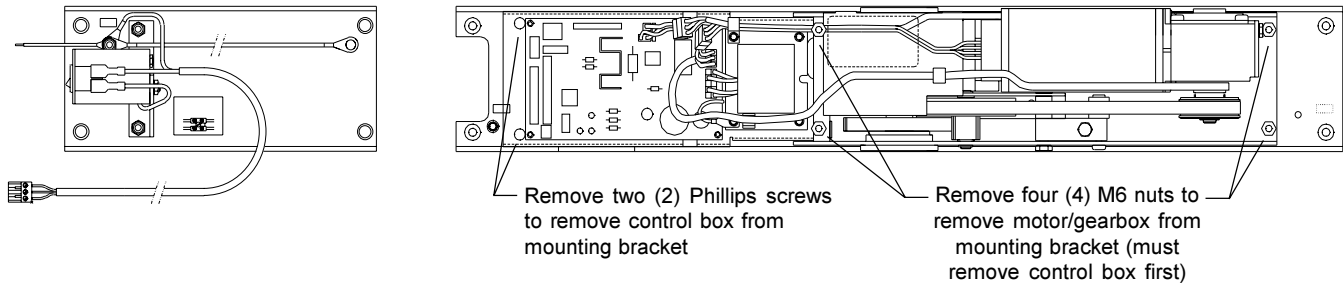

- 2.2. Prepare header/frame and door:
- 27" Pull System ..... see page 6
  - Full Length Pull System ..... see page 6
  - 27" Push System ..... see page 7
  - Full Length Push System ..... see page 7
  - Double Push System ..... see page 8
  - Low Ceiling Application ..... see page 8



#### NOTE

For push units with a reveal greater than 6" refer to the installation sheet included in the extended arm packaging.

- 2.3. Install operator mounting bracket on header/frame. For full length systems, also install switch bracket on header/frame.
- 2.4. Install motor/gearbox on operator mounting bracket, then install control box on bracket.
- 2.5. Go to "Wiring" on page 9.

## 2. OPERATOR INSTALLATION (continued)

### 27" Pull System Frame/Header and Door Preparation

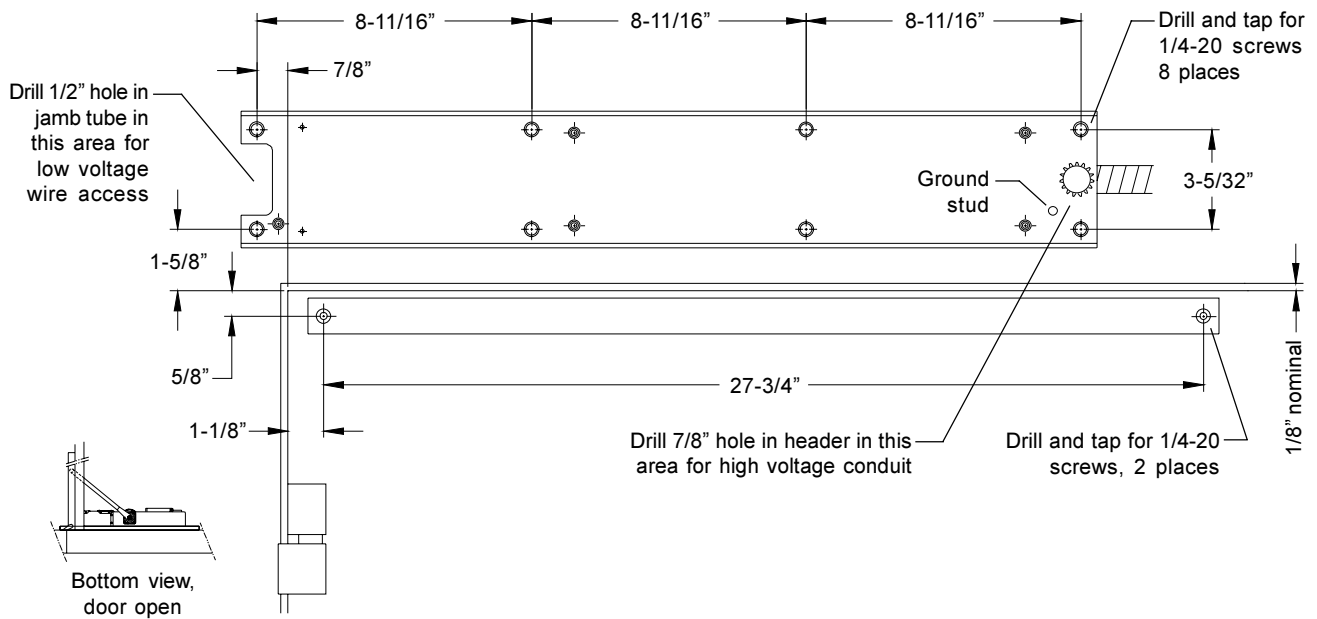

### Full Length Pull System Frame/Header and Door Preparation

Center operator cover (with end caps removed) over opening and mark a vertical line at each end. Align ends of operator mounting bracket and switch bracket with vertical lines and adjust vertical position per diagram below. Mark and prepare mounting holes.

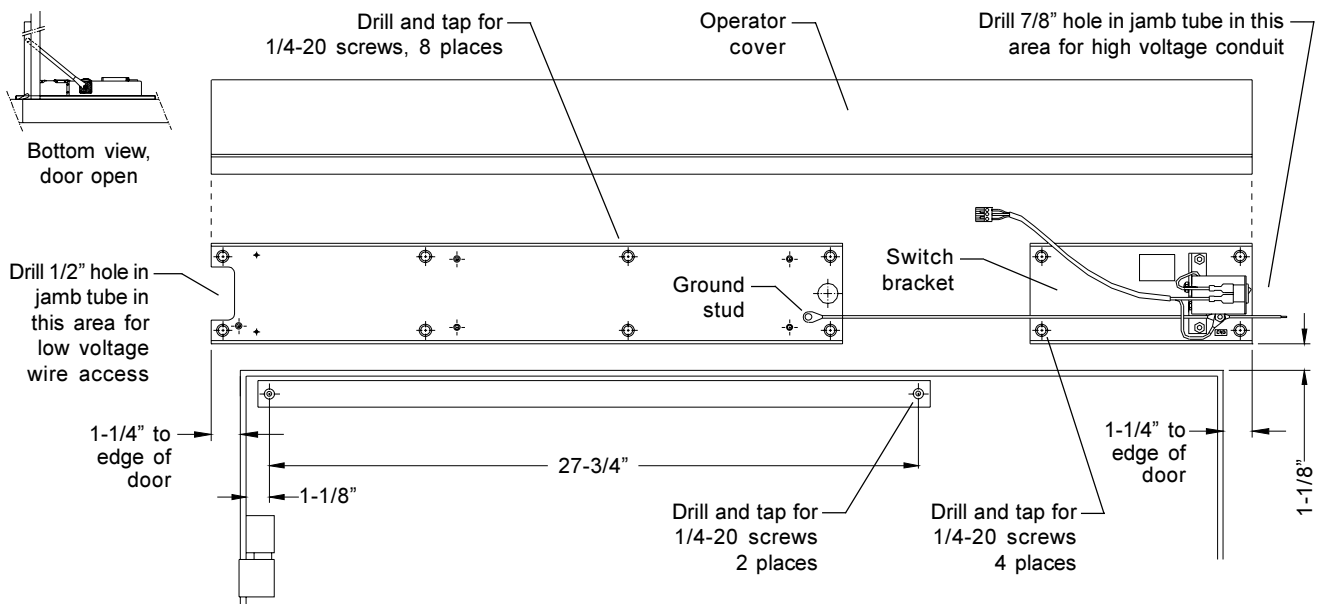

## 2. OPERATOR INSTALLATION (continued)

### 27" Push System Frame/Header and Door Preparation

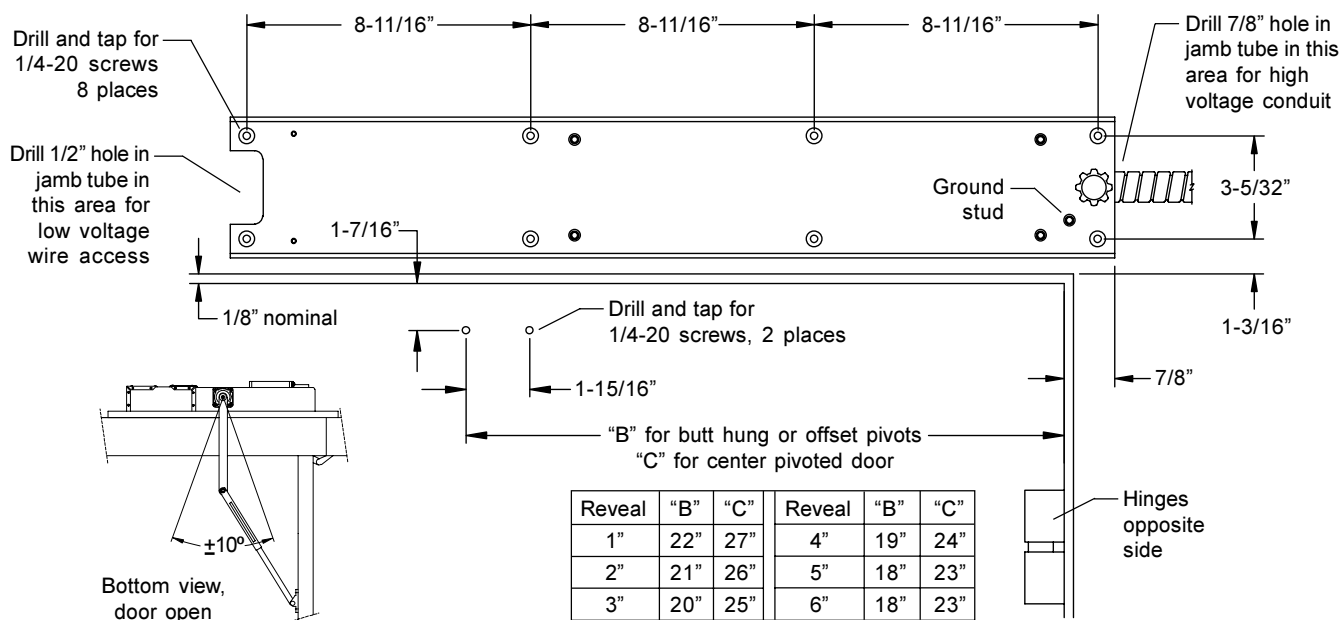

### Full Length Push System Frame/Header and Door Preparation

Center operator cover (with end caps removed) over opening and mark a vertical line at each end. Align ends of operator mounting bracket and switch bracket with vertical lines and adjust vertical position per diagram below. Mark and prepare mounting holes.

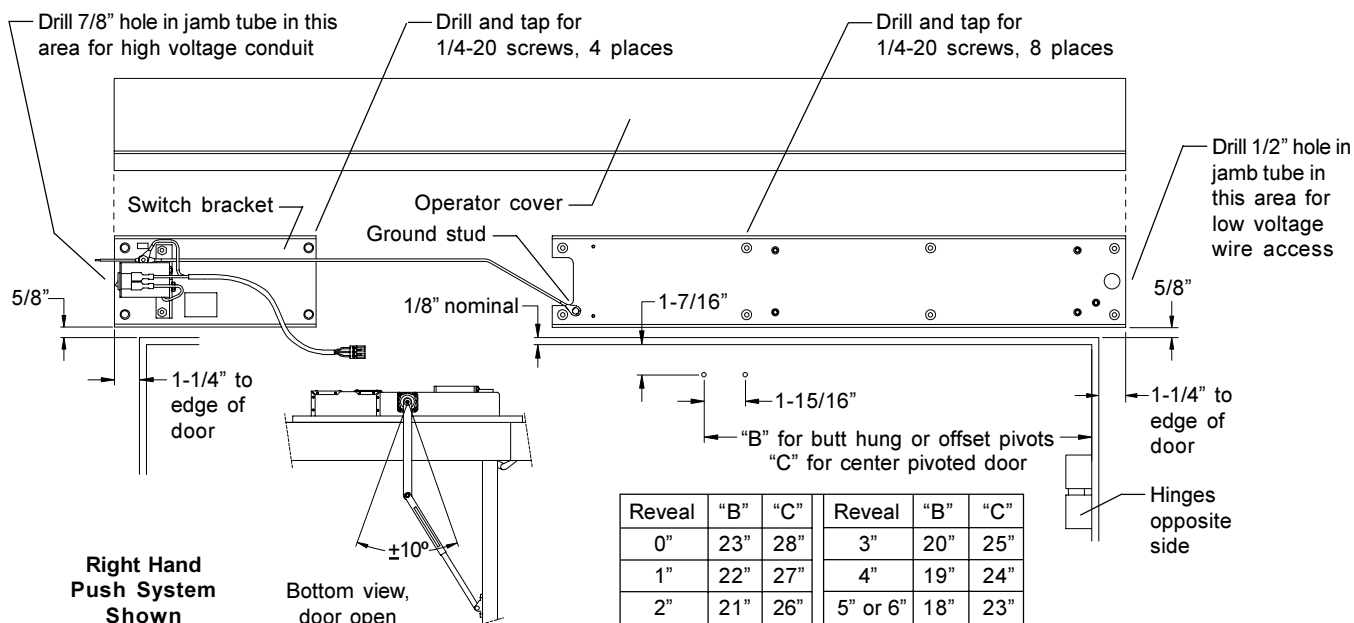

## 2. OPERATOR INSTALLATION (continued)

### Double Push System Frame/Header and Door Preparation

Center operator cover (with end caps removed) over opening and mark a vertical line at each end. Align ends of operator mounting bracket and switch bracket with vertical lines and adjust vertical position per diagram below. Mark and prepare mounting holes.

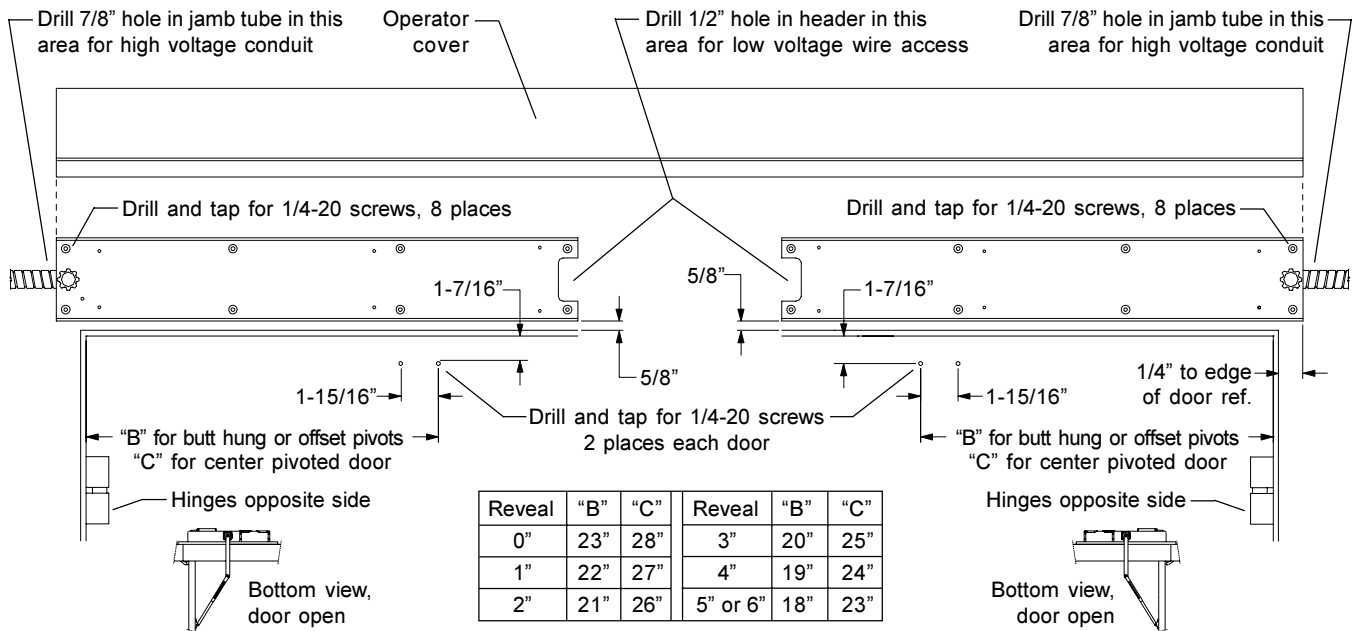

### Low Ceiling Application (27" Push System Only) Frame/Header and Door Preparation

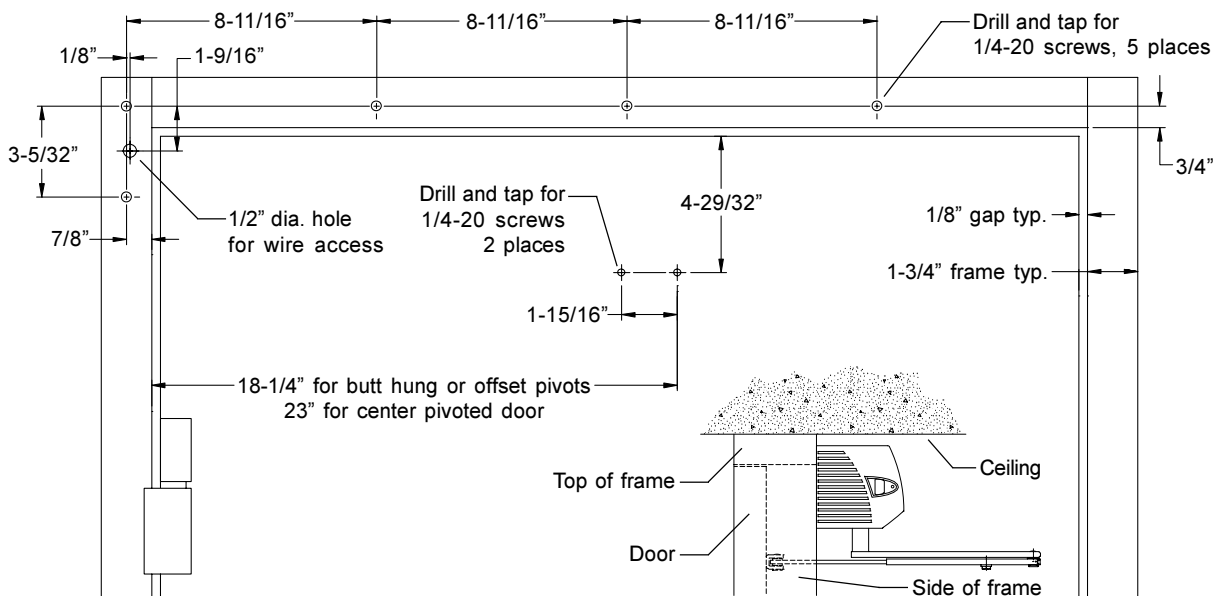



## 3. WIRING



### CAUTION

- Make sure all wires are properly dressed and secured to prevent interference.
- Route all wiring away from moving parts, sharp edges, and heat sources.
- Use copper conductors only.
- Do not modify the factory wiring or connect into existing electrical circuits or devices.

3.1. Refer to the appropriate wiring diagram for the standard control box (page 10) or the premium control box (page 11), and connect the following cables:

- Ground Cable (ground the operator properly with a separate green ground wire)
- Hall Effect Cable (**do not** wrap the Hall Effect cable around the Motor Power cable)
- Motor Power Cable (**do not** wrap the Motor Power cable around the Hall Effect cable)
- Main Power Cable
- Control Box Power Cable

3.2. Connect Activate, Safety, 3-Position Switch, and Lock accessories as needed. Refer to the accessory instructions for any accessories used. Do not connect any remote activating device to the door unless it is located within line of sight of the door. An SO Kit is required if DC powered accessories are powered from the 17 VAC control box terminals.

3.3. When wiring is complete, go to “Arm and Cover Installation” on page 12.

### “NO,” “NC,” and “AUX. ACT.” Circuits

- “NO” and “NC” are for a de-energized relay.
- The relay is not energized when the 3-position switch is OFF and when the door is opening.
- The relay is energized when the 3-position switch is set to AUTO and when the door is closed.
- Connect fail secure locks to “NC.”
- Connect fail safe locks to “NO.”
- The “AUX. ACT.” circuit is used for special applications only.

### To Change Fuse

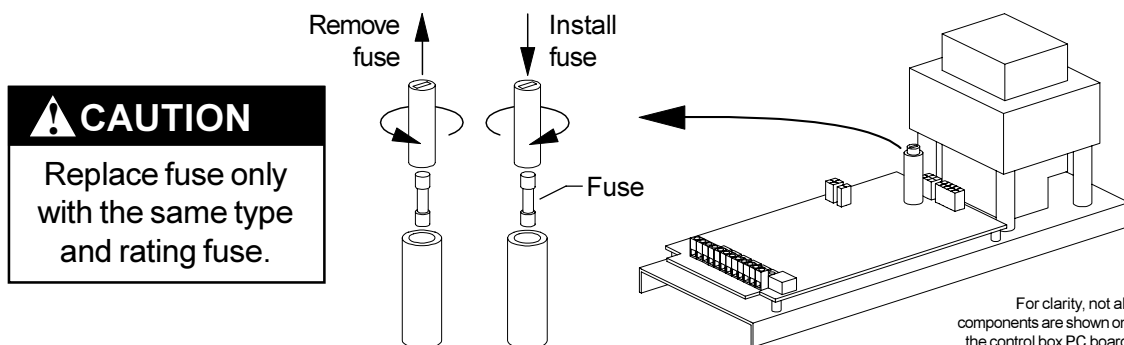

### 3. WIRING (continued)

## Standard Control Box Wiring

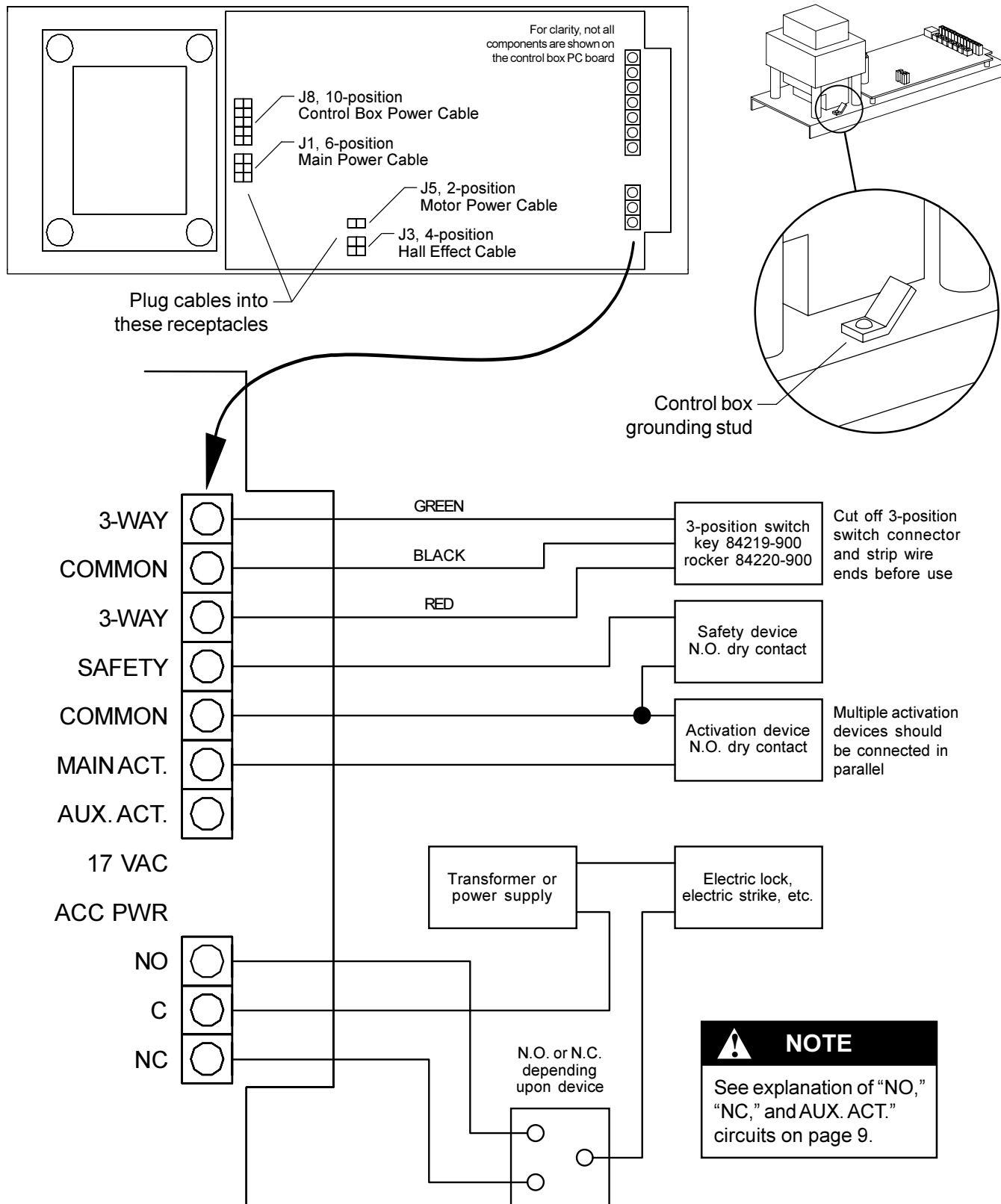

### 3. WIRING (continued)

## Premium Control Box Wiring

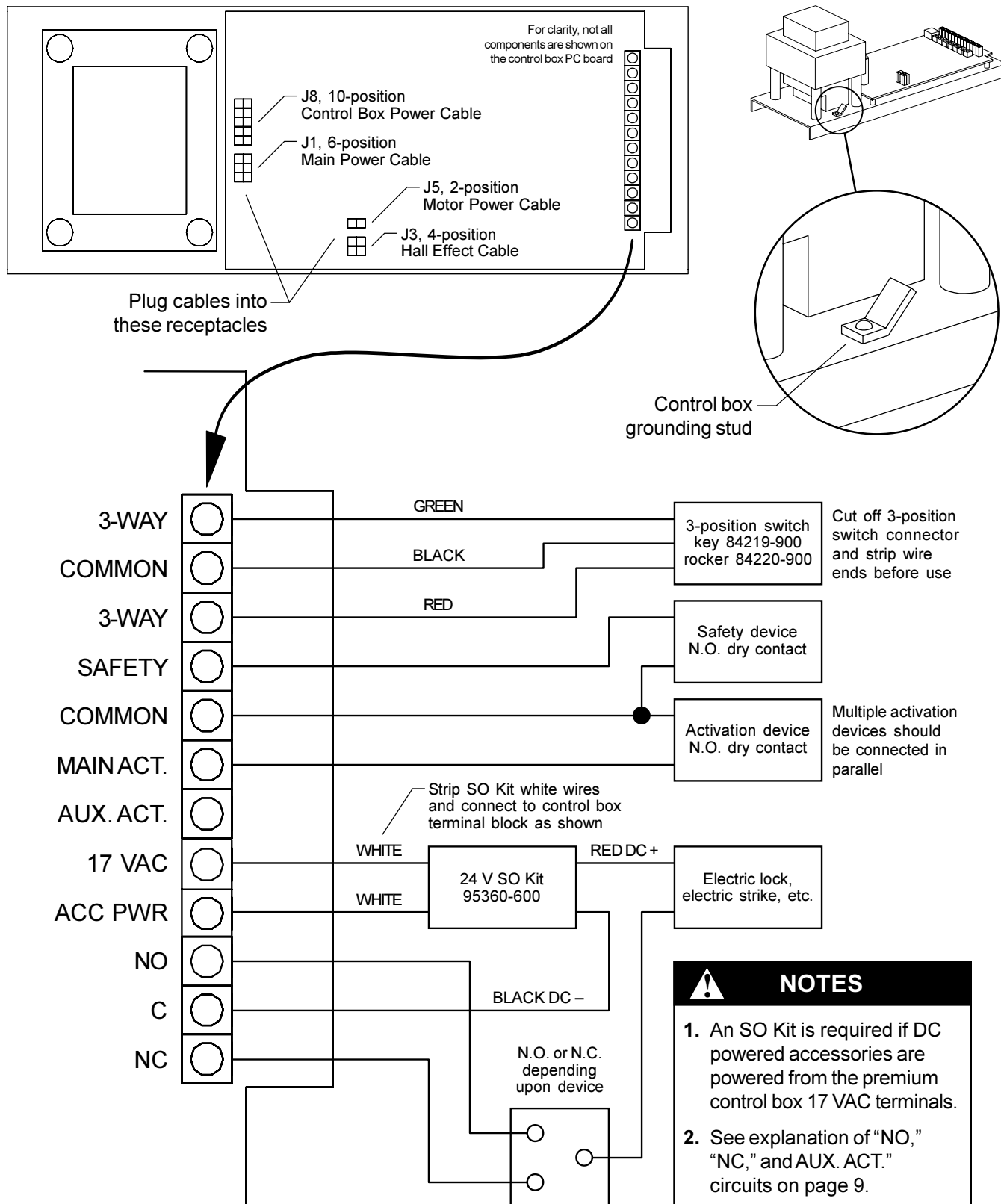

## 4. ARM AND COVER INSTALLATION



### WARNING

**KEEP HANDS, CLOTHING, WIRES, TOOLS, ETC. AWAY FROM THE OPERATOR MOTOR WHEN THE OPERATOR IS TURNED ON.**

- 4.1. Make sure the operator power switch is turned off.
- 4.2. Install a jumper across the control box **MAIN ACT.** and **COMMON** terminals.
- 4.3. Turn on the operator power switch. The operator motor will activate to the full open position.
- 4.4. Attach the arm to the operator spindle loosely with the 8 mm socket head screw.

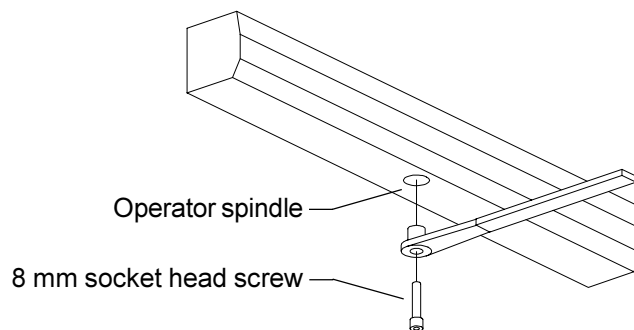

- 4.5. Attach the arm to the door:

- 4.5.1. For push systems, attach the push arm shoe to the door.

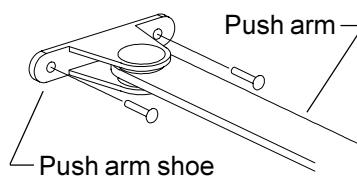

- 4.5.2. For pull systems, slide the pull arm roller into the track, insert a track cap on each end of the track, and attach the track to the door.

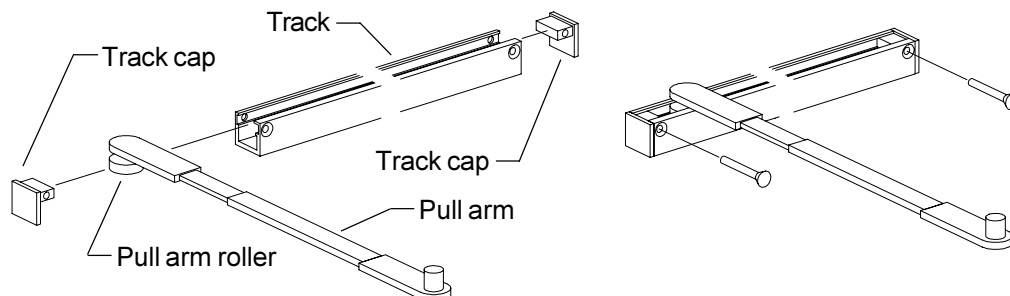

## 4. ARM AND COVER INSTALLATION (continued)

### 4.6. Adjust the arm:

4.6.1. For pull systems, remove the locking screws in the arm.

4.6.2. For push systems, remove the locking screws in the arm.

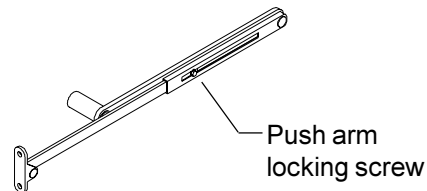
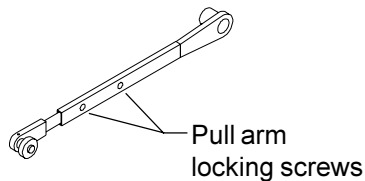

4.6.3. Keep the door in the full open position and adjust arm length as necessary with the door in the full open position. When the arm is adjusted to the proper length, tighten the 8 mm socket head screw that secures the arm to the operator spindle, then tighten/install the locking screw(s) in the arm.

4.7. Turn off the operator power switch. The door closes.

4.8. Remove the jumper from the control box **MAIN ACT.** and **COMMON** terminals.

4.9. Test the operator (see “Operational Check” on page 14) and then continue with step 4.10.

4.10. Adjust the operator as required (see “Operator Adjustment” on page 15) and then continue with step 4.11.

4.11. Snap end caps into the cover and secure with the two 6-32 round head screws provided.

4.12. Snap optional end cap insert (from screw bag) into the end cap opposite the on/off switch.

4.13. For full length systems, snap the insert into the arm slot that is not being used.

4.14. Install the cover assembly and on the operator.

4.15. Release the operator for service (see “Release for Service” on page 16).

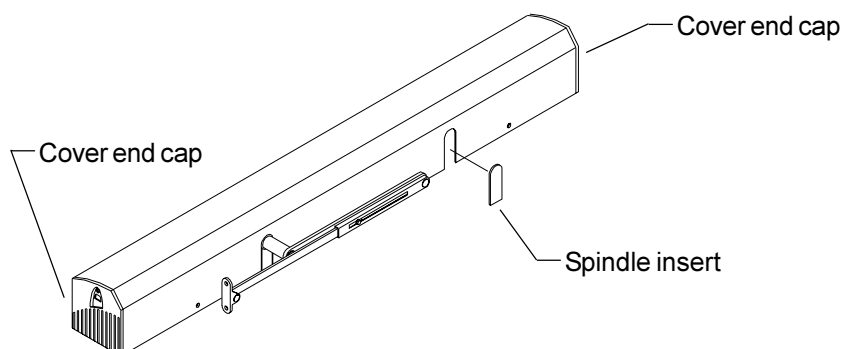

## 5. OPERATIONAL CHECK

- 5.1. Set the 3-position switch to AUTO and turn on the operator power switch.
- 5.2. Activate the operator using an activation device. The operator will perform one sizing cycle.  
**Sizing Cycle:** Occurs when the door is activated for the first time after power has been turned on. During the sizing cycle, the door opens and closes one time.
- 5.3. If the door does not open at all during the sizing cycle:
  - Check door for binds.
  - If an electromechanical lock is being used, check that the lock disengages before the operator opens the door.
  - Check fuse(s), circuit breaker, and connections.
  - Adjust the operator and check door operation (see “Operator Adjustment” on page 15):
    - Opening speed: ..... maximum
    - Back check speed: ..... maximum
    - Hold open time delay: ..... minimum
    - Back check position: ..... 50%
    - Latch position: ..... maximum
    - Closing speed: ..... maximum
    - SW1 #1, #2, #3, #4: ..... off
- 5.4. If the door does not open fully during the sizing cycle:
  - Check door for binds.
  - Increase the back check speed slightly and check door operation. Continue increasing back check speed until the door opens fully.
- 5.5. If the door slams open, decrease the back check speed slightly and check door operation. Continue decreasing back check speed until the door opens without slamming.
- 5.6. After the sizing cycle is complete and the door is closed, apply a maintained activation signal and check that the door remains open while the activation signal is applied.
- 5.7. If a door safety device is being used:
  - 5.7.1. Activate the door and then activate the safety device while the door is open. The door should not close while the safety device is activated. Next, deactivate the safety device. The door should close after the hold open time delay expires.
  - 5.7.2. With the door closed, activate the safety device, then activate the door. The door should not open while the safety device is activated. Next, deactivate the safety device. The door should open.
- 5.8. When the door is operating properly, continue with step 4.10 on page 13.

## 6. OPERATOR ADJUSTMENT

See table below and diagrams on page 16 for operator feature adjustment. After adjusting, cycle the door several times and check for proper operation, then continue with step 4.11 on page 13.

<b>NOTE</b>
<p>Adjust the operator for the slowest operation practical in accordance with the latest revisions of Americans with Disabilities Act, ANSI/BHMA A156.19 Standard for Power Assist and Low Energy Power Operated Doors, and local codes.</p> <ul style="list-style-type: none"> <li style="width: 50%;">• Opening Speed: 3 sec or more</li> <li style="width: 50%;">• Latch Location: 10 degrees or more</li> <li style="width: 50%;">• Closing Speed: 3 sec or more</li> <li style="width: 50%;">• Latch Speed: 1.5 sec or more</li> </ul>

Feature	Control	Description	Counterclockwise	Clockwise
Opening speed	P1	Controls opening speed of any normal weight and size door	Slower	Faster
Back check speed	P2	Controls speed of door near full open position to prevent door slamming open	Slower	Faster
Hold open time delay	P3	Controls length of time door remains fully open following an activate signal, 1 to 30 sec	Less time 1 sec minimum	More time 30 sec maximum
Back check position	P4	Determines distance at which door begins to decelerate near the full open position	Less back check	More back check
Latch position	P5	Determines distance at which door begins to decelerate near the full closed position	Less latch	More latch
Closing speed	P6	Controls closing speed of any normal weight and size door	Slower	Faster
Delayed activation	SW1, #1	When switched ON, causes a 1 sec delay between activation signal and door opening; this allows time for most electric locks to disengage before the operator opens the door		
Push-N-Go	SW1, #2	When switched ON, pushing door open 5 degrees causes operator to open door for the remainder of the opening cycle		
Power Boost (Premium Control Box only)	SW1, #3	When switched ON, electronically increases closing force of door from 9 lbs to 18 lbs to close door against high winds or stack pressure; Power Boost turns on for 5 sec after door comes to a stop at least 80 degrees into its closing cycle		

## 6. OPERATOR ADJUSTMENT (continued)

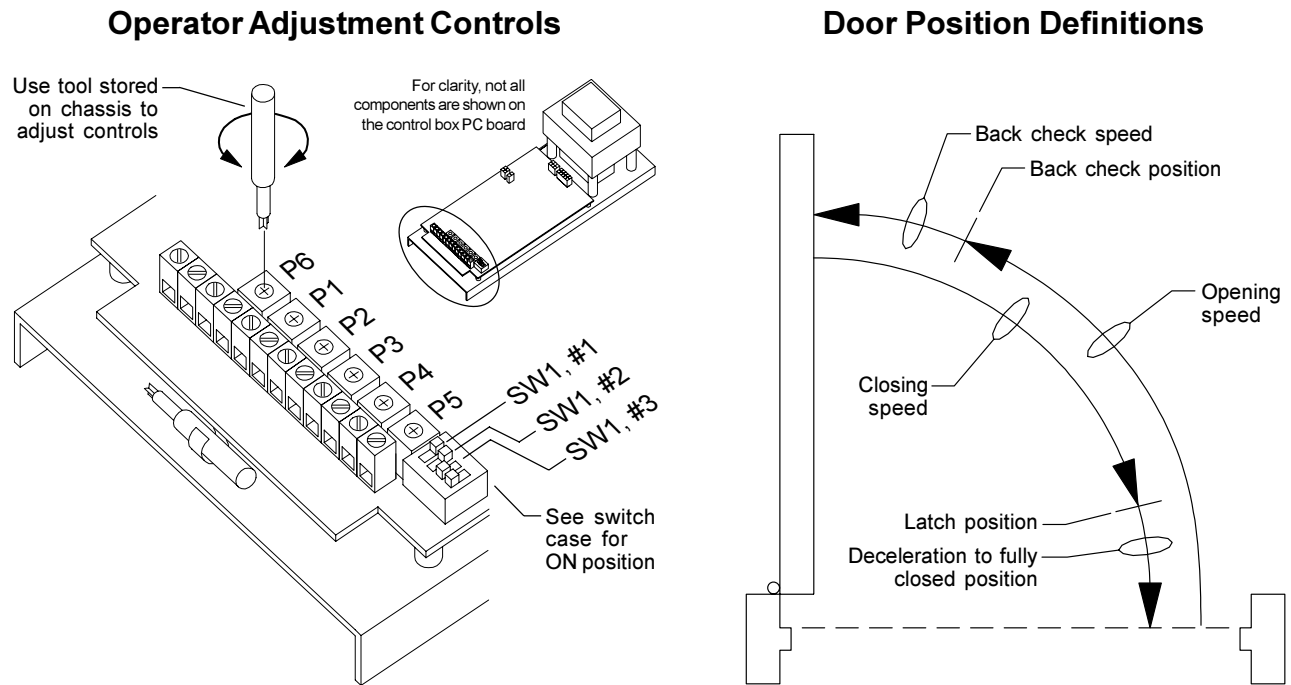

## 7. RELEASE FOR SERVICE

- 7.1. Remove all tools, installation equipment, and debris from the vicinity of the door.
- 7.2. Install all safety, traffic control, and instruction decals on the door as required by the latest revision of ANSI/BHMA A156.19. **This is very important! Failure to do this leaves the installer LIABLE for any accident that might occur. This must be done!**
- 7.3. Verbally instruct the owner or person in charge of the proper operation of the door.
- 7.4. Instruct the owner or person in charge to routinely inspect the door for the following:
  - Occasional damage
  - Developing problems
  - Minor preventive maintenance
- 7.5. Instruct the owner or person in charge who and where to call for service when required.



### IMPORTANT

Make sure to install all safety, traffic control, and instruction decals on the door as required.