



Series 96000 Slide Control

Installation Instructions

DOR - O - MATIC®

7350 W. Wilson Ave.
Harwood Heights, IL 60706

Toll Free:	1-800-543-4635
In Illinois:	708-867-7400
Sales FAX:	708-867-0291
Technical Support	1-888-942-9945
www.doromatic.com	

INSTALLATION

1. Preparation: Refer to Series 96000 Slide Installation Manual (DOM #96000-984) for header preparation instructions.

NOTE: Always disconnect main power to operator prior to servicing or cleaning.

2. Final Wiring Connections:

The Series 96000 header comes from the factory “pre-wired” to minimize installation time at the job site. Connect main power to the terminal block at the end of the header (Figure 1). Connect accessories to the terminal block on the safety beam bracket or control box as needed (Figure 2). Refer to the instruction manual of the accessory for complete wiring details.

- A. Use a 115 volt, 60Hz, fused, 15 amp, 3-wire power supply.
- B. Externally route the main power to the side of the header with the terminal block.
Do not run the main power in the wire channel the length of the header.
- C. When wiring the header, place the main power in one wire channel and the accessory wiring in the other.
- D. Secure all conductors and connections against physical damage.
- E. Route all wiring away from moving parts, sharp edges and heat sources. Manually and slowly push doors open and closed and observe that parts do not interfere with the wiring.
- F. Use copper conductors only.

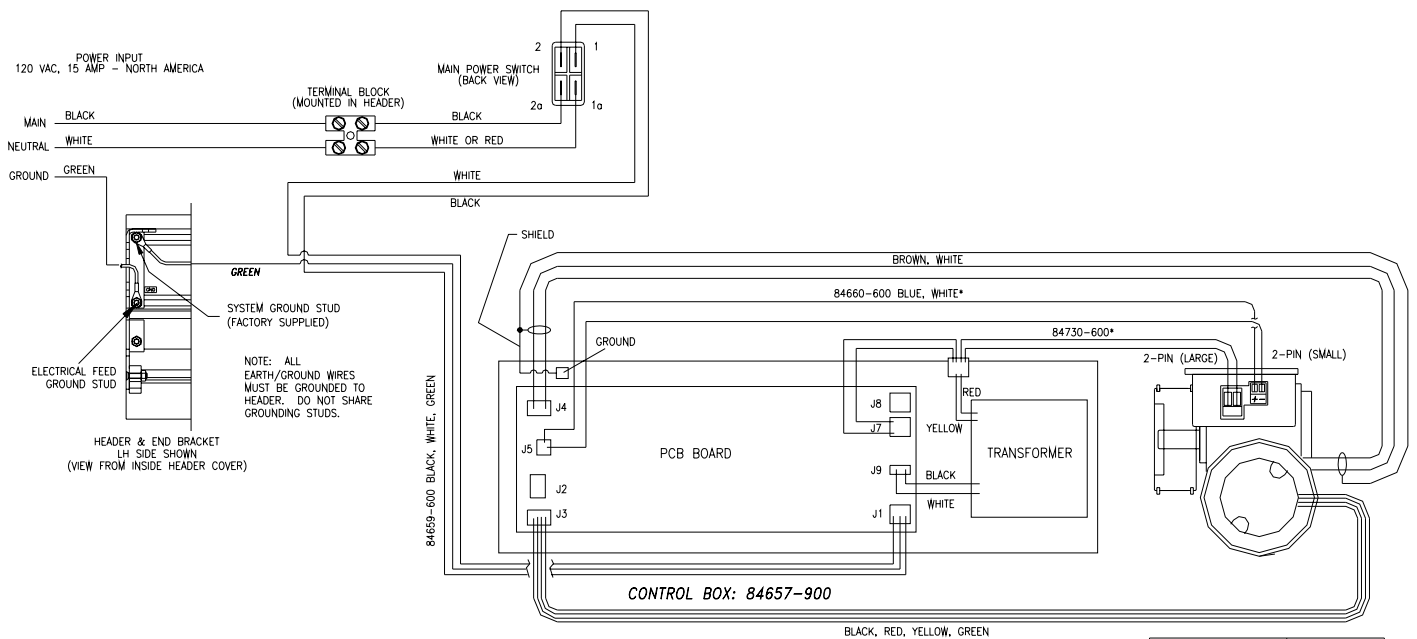

ELECTRIC LOCK WIRING

MOTOR GEAR BOX	PART NUMBER
STANDARD	84732-000
FAIL-SECURE LOCK*	84733-000*
FAIL-SAFE LOCK*	84734-000*

* = USED ONLY WITH FAIL-SECURE AND FAIL-SAFE LOCKS

FIGURE 1: POWER WIRING DIAGRAM

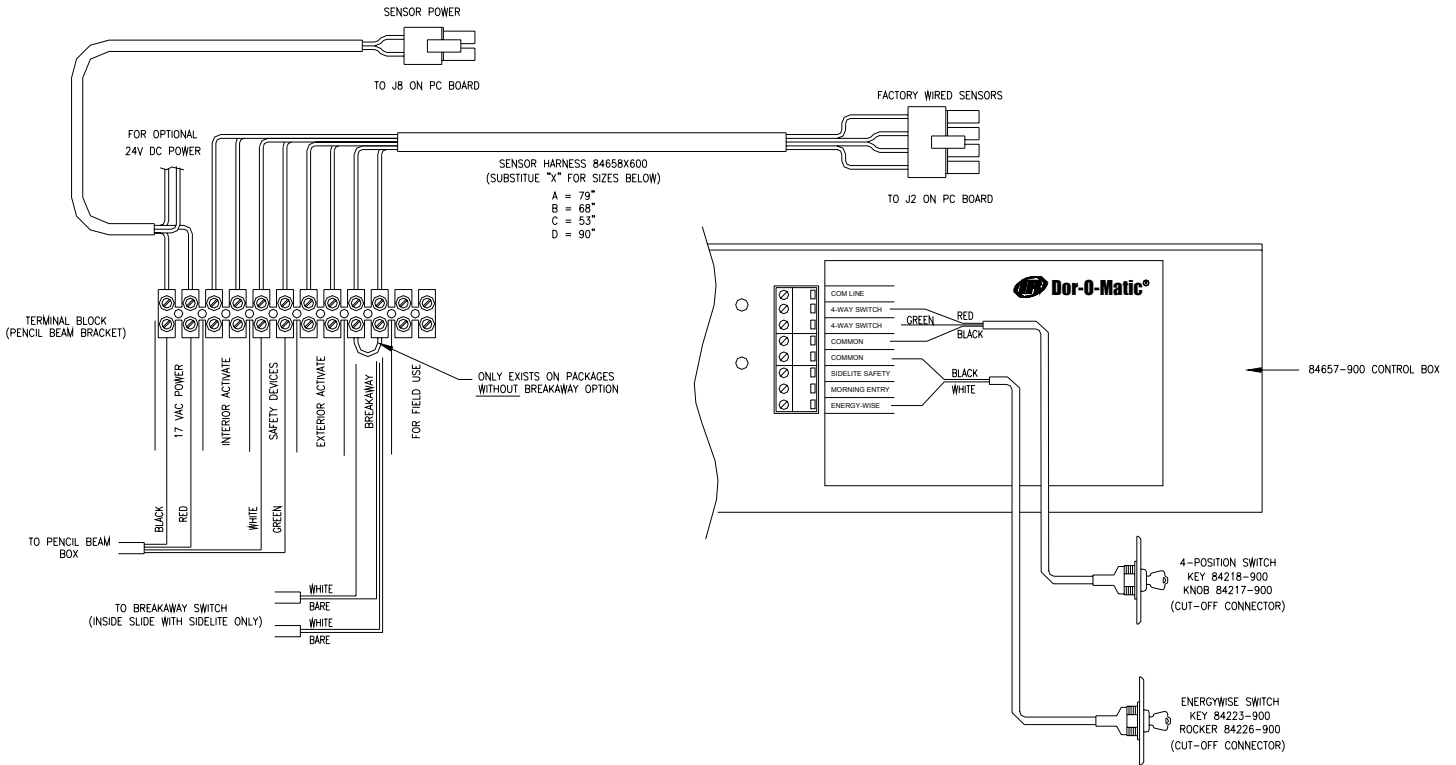

FIGURE 2: ACCESSORY WIRING DIAGRAM

3. Operational Check and Adjustments:

NOTE:

- Refer to the latest revision of ANSI/BHMA A156.10-1999 Standard for Power Operated Pedestrian Doors for all settings and adjustments.
- A flashing keypad indicates that keypad changes were not accepted. Changes will be accepted once the door is fully open or closed.
- Upon power-up, the display remains blank. Also, the display will go blank after (5) minutes of inactivity. If the display is blank, depressing any two (2) keys for three (3) seconds will enable the display. Once enabled, the display will show OS setting and its corresponding value.
- For all keypad values, the lower number represents slower or minimum values while the higher number represents faster or maximum values.
- **Keypad adjustments will not be accepted until the sizing mode is completed.**

Setting - Up or Down pushbuttons:

Scrolls through the available settings.

Value - Up or Down pushbuttons:

Scrolls through the available values for each setting.

Test Activate pushbutton:

When pressed, this button will provide an activation signal to the door.

Default pushbutton:

To revert back to factory settings, press and hold the default button for 5 seconds.

1. Close doors.
2. If the 4-position switch is used, be sure it is in the "2-way" position before proceeding.
3. Apply power to the system using the main power switch on the header/cover.
4. Apply an activation signal (activate inside or outside motion sensor, press keypad "test activate" or momentarily move the 4-way to the hold position).
5. Observe sizing cycle. If door slams open or closed, reduce sizing speed (SS) setting. Remove power and repeat steps 3 to 5.
Note: Allow the door to remain at the fully closed position for a minimum of one (1) second to complete the sizing mode.
Caution: If the door sizing speed is set too fast, blown fuses and/or a tripped circuit breaker may occur if the doors are activated when manually locked.
6. After sizing is complete, make adjustments to other settings as needed.

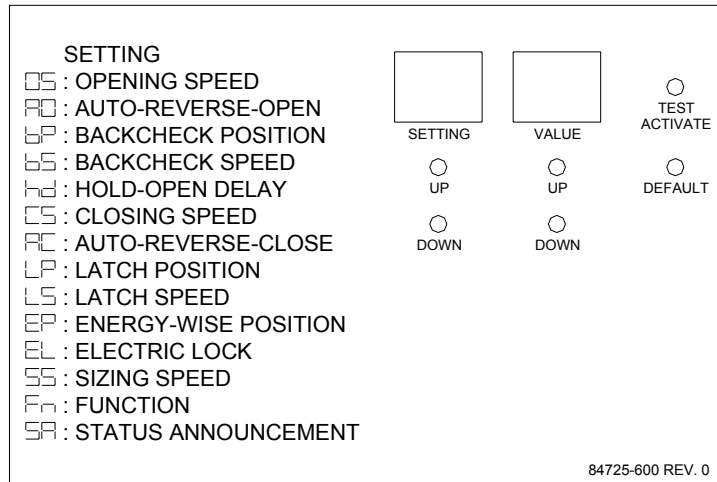

KEYPAD LABEL DRAWING

Setting	Setting Display	Value Ranges	Factory Default Settings	Description
Opening speed	OS	1 to 99	85	Controls the opening speed of the door. It is recommended that the door be operated as slowly as practical for the traffic conditions.
Auto-reverse opening	AO	1 to 99	75	Controls the amount of force required to reverse the door when opening (see FEATURES).
Backcheck position	bP	1 to 32	08	Controls where backcheck position starts.
Backcheck speed	bS	50 to 99	80	Controls the door speed during backcheck.
Hold Open Delay	hd	1 to 32	01	Controls the amount of time the door stays open. If a presence sensor is not installed, the time delay must be at least 4 seconds.
Closing speed	CS	1 to 99	75	Controls the closing speed of the door. It must not exceed 1 ft/sec.
Auto-reverse closing	AC	1 to 99	50	Controls the amount of force required to reverse the door when closing (see FEATURES).
Latch position	LP	1 to 32	07	Controls where latch position starts. It must be at least 2 inches from the fully closed position.
Latch speed	LS	50 to 99	85	Controls the door speed during latch.
Energy-wise	EP	50 to 75	50	Adjusts the open position of the door from 50% to 75% of full open when energy-wise switch is set to narrow.
Electric Lock	EL	ON or OF	OF	Enables (ON) or disables (OF) the electric lock delay. If EL is set to OF, the door opens immediately upon reception of the activation signal. If EL is set to ON, when the door is fully closed, there is a 1 second delay between reception of the activation signal and the actual opening of the door. This delay allows most electric or magnetic locks time to unlock before the door opens.
Sizing speed	SS	50 to 99	85	Controls the speed of door during sizing.
Function	Fn	00	00	This setting not used at this time.
Status Announcement	SA	00	00	This setting not used at this time.

Reset Power:

If main power needs to be reset for any reason, power must remain off for a minimum of ten (10) seconds to allow proper discharge of internal circuitry.

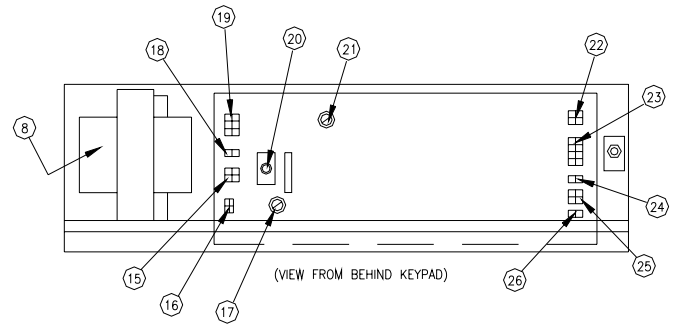
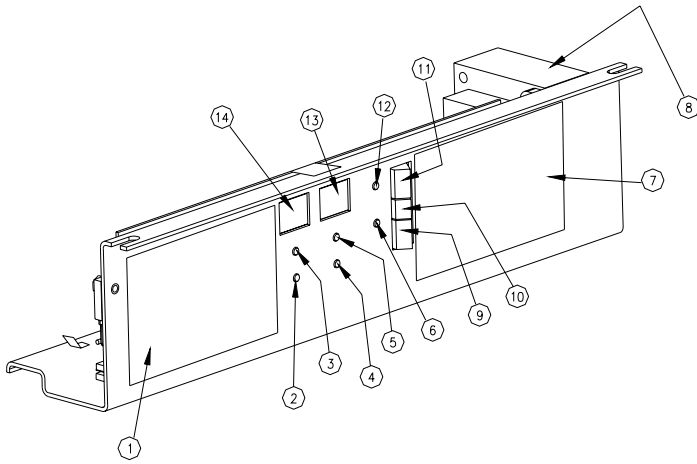

1. Keypad Label	10. J10C	19. J1 (AC In)
2. Setting Down	11. J10A	20. CB1
3. Setting Up	12. Test Activate Push Button	21. F1 (Main Fuse)
4. Value Down	13. Value Display	22. J3 (Hall Effect Sensor)
5. Value Up	14. Setting Display	23. J2 (Factory Wired Sensors)
6. Default Setting Push Button	15. J7 (Transformer Secondary)	24. J5 (Electric Lock Circuit)
7. Description Label	16. J8 (Sensor Power)	25. J6 (Not Used)
8. Transformer	17. F2 (Sensor Fuse)	26. J4 (Motor Drive)
9. J10B	18. J9 (Transformer Primary)	

FIGURE 3: CONTROL BOX FEATURES
CB1 (MOTOR/CONTROL CIRCUIT BREAKER)

4. Operational Walk-Through Test:

NOTE: It is assumed that during the installation process, any problems would have been found and corrected before this point. However, it is recommended that a complete walk-through test now be performed.

- A. Give the system an activation signal. The door should open smoothly and silently to the back check point, where it should slow down rapidly and drift into the fully open position without slamming.
- B. Maintain the activation signal to verify that the door does **NOT** time out and **close** while being activated.
- C. If a door safety device is used, step into the door opening. Remain in the door opening making sure that the door does **NOT** close.
- D. Step out of the door opening. After both the activating area and door opening are clear, the door should time out at the pre-set time delay and begin to close. The door should close quietly and smoothly to the latch point, where it rapidly slows down and drifts into the fully closed position without slamming.

5. Release of the System for Use:

- A. Remove all tools and installation equipment, and clean any debris from the vicinity of the door.
- B. Install all safety, traffic control, and instruction decals to the door as required. **THIS IS VERY IMPORTANT!** Failure to do this leaves the installer **LIABLE** for any accident that might occur. **THIS MUST BE DONE!**
- C. Verbally explain the proper operation of the door system to the owner or to the person in charge.

6. For Doors that are manually/mechanically secured:

- A. Locking:
 - 1) Place switch in "OFF"
 - 2) Allow door to close completely
 - 3) Secure door
- B. Unlocking inside:
 - 1) Unsecure door
 - 2) Place switch in "1-WAY" or "2-WAY"
 - 3) Activate door once
- C. Unlocking outside:
 - 1) Unsecure door
 - 2) Activate morning entry or manually open door
 - 3) Place switch in "1-WAY" or "2-WAY"

FEATURES

1. **Easy Open:** When the door is fully closed and manually opened a few inches, it will automatically open the rest of the way.
2. **Adjustable Automatic Reversing:** If the door is stalled during the closing cycle, it will automatically stop and reverse to the fully open position. Then the door will close to the point of obstruction and drop to slow speed, looking for the obstruction. This cycle will occur 5 times until the obstruction is removed. After the fifth cycle, the door will stop, requiring an activation signal or manual opening to re-start the system. If the door is stalled during the opening cycle, it will automatically stop and reverse to the fully closed position. The door will remain closed until the next activation signal, at which point it will open normally. **Reversing forces should be adjusted in accordance with all applicable safety codes.**
3. **Energy-wise (Optional):** The energy-wise feature allows the customer to reduce the opening size. When the weatherwise switch is set to "NARROW", the door will only open from 50% - 75% of the normal door opening.
(If energy-wise not used, door opens to 100% of opening)
4. **Beam Shut-Off:** So the door is fully closed, the beam signal is disregarded so that it cannot be used to open the door. Once the door is activated, the beam signal is allowed to re-open the door if either safety beam is interrupted during the closing cycle.
5. **4-Way Switch Operation:**
When the 4-Position Switch is set to:
"OFF", easy open, interior and exterior activation will not open the door. The morning entry switch will open the door.
"1-WAY", only interior activation will open the door. Exterior activation will not open a closed door but will re-open a door in the closing cycle.
"2-WAY", interior and exterior activation will open the door.
"HOLD OPEN", the door will remain open.

If the 4-Position Switch is not used, Default = "1-WAY".
6. **Morning Entry (Optional):** The morning entry feature allows outside entry using a keyswitch when the 4-way switch is in the OFF position. The morning entry switch connects to the controller terminal block between COMMON and MORNING ENTRY (see Figure 2).
7. **Sidelite Safety (Optional):** The sidelite safety feature slows the opening speed of the door when an obstruction is sensed in the sidelite area. The sidelite safety sensor contacts connect to the controller terminal block between COMMON and SIDELITE SAFETY (see Figure 2).

DO'S AND DON'TS

1. Do **NOT** try to use this operator on large, heavy doors without checking with the factory first.
2. Do **NOT** connect any remote activating device to the door unless it is located within the "line of sight" of the door.
3. Do **NOT** attempt to use a fuse larger than specified.
4. Do **NOT** attempt to modify the factory wiring or connect any wiring into an existing electrical circuit or any other electrical device.
5. **Do** make certain that the operator is connected to a dedicated 115 volt circuit from the main circuit breaker panel.
6. **Do** make certain that the operator is properly grounded with a separate green wire.
7. **Do** make certain that all connections are proper and secure before turning the power on.
8. **Do** make certain that all wires are properly dressed and secured to prevent any interference.
9. **Do** make certain that all safety labels and instruction decals relating to door operation are properly applied to the door before leaving the job.
10. **Do** verbally instruct the owner or person in charge of the proper operation of the door.
11. **Do** disconnect main power to the operator prior to servicing or cleaning.
12. **Do** instruct the owner or person in charge of his responsibility of inspecting the door for the following:
 - A. Occasional damage
 - B. Developing problems
 - C. Minor preventative maintenance
 - D. Who and where to call for service when required.